

LYDOS PLUS NEW



1. ADVANCED PERFORMANCE

- / WaterPlus technology*: up to 16%** more hot water available
- / ECO EVO function powered by CoreTECH: up to 14% energy saving
- / Compliant with top ESWH regulations

ENERGY CLASS



2. FULL COMFORT

- / Weekly programming with up to 2 daily heating cycle
- / Shower ready icons showing the number of showers currently available
- / Visualization of remaining heating time before reaching set temperature
- / Holiday mode to save energy during long absences
- / Absolute safety system preserving the good functioning of the product

3. EVERLASTING QUALITY

- / Premium and robust environmental-friendly insulation material
- / Oversized magnesium anode to fight against corrosion



TECHNICAL DATA

		LYDOS PLUS 50 V 1,8k EN EU	LYDOS PLUS 80 V 1,8k EN EU	LYDOS PLUS 100 V 1,8k EN EU
Installation		V	V	V
Capacity	L	50	80	100
Max working pressure	bar	8	8	8
Power	KW	1,8	1,8	1,8
Voltage	V	230	230	230
IP class	IP	IPX3	IPX3	IPX3
Max working temp	°C	80	80	80
Heat dispersion 65°C	KWh/24h	0,99	1,35	1,56
Heating time ΔT 45C	h,min	1,27	2,11	2,46
Weight	Kg	16	20,5	24

DIMENSIONS

A	mm	528	733	885
---	----	-----	-----	-----

CODE

	3201869	3201870	3201871
Erp class	B	B	B
Tapping profile	M	M	M

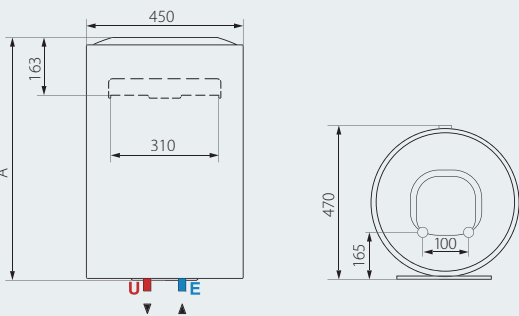

LEGEND

- E** Cold water inlet G 1/2"
- U** Hot water outlet G 1/2"

The capacity indicated in this catalogue identifies the product category.
The effective capacity of the product is given in the relevant technical documentation provided with the product.

* Patented in Spain, patent pending in IT, FR, TK, RU, CN, VN, UAE
** Maximum estimated saving, depending on models. Comparison made using V40 test results at maximum operating temperature between current ATG products and new ATG products equipped with WaterPlus Technology.